

Service Managed Gateway™

Configuring VLAN and CDP on an SMG



Issue 1.3
Date 22 June 2010

1	About this document	3
1.1	Scope	3
1.2	Readership	3
1.3	Terminology	3
2	Introduction to VLAN.....	4
2.1	Configuring the SMG for VLAN.....	4
2.2	Configuring an individual interface for VLAN.....	5
2.3	Viewing VLAN tags	6
2.4	Deployment scenario example	7
2.5	Debugging VLAN	8
3	CDP	10
3.1	Configuring the SMG for CDP.....	10
3.2	CDP flows	11
3.3	Debugging CDP	11
3.3.1	Tracing using the command line	11

© 2010 Virtual Access (Irl) Ltd. This material is protected by copyright. No part of this material may be reproduced, distributed, or altered without the written consent of Virtual Access. All rights reserved. All trademarks, service marks, registered trademarks and registered service marks are the property of their respective owners. Virtual Access is an ISO 9001 certified company.

1 About this document

1.1 Scope

This configuration guide explains:

- how to set up and configure VLAN and CDP on a Service Managed Gateway (SMG); and
- the basic functionality of VLAN and CDP on an SMG

1.2 Readership

This document is for engineers who have previous experience configuring and managing SMGs.

1.3 Terminology

CDP	Cisco Discovery Protocol
QoS	Quality of Service
SMG	Service Managed Gateway
VLAN	Virtual Local Area Network
VoIP	Voice over Internet Protocol

2 Introduction to VLAN

The Virtual Access SMG supports 802.1Q tagged-based VLAN. Tagging is the process of adding a 4 byte tag containing the VID (VLAN ID) to an Ethernet frame.

Hosts send traffic with or without a VLAN tag. The Virtual Access SNG assigns this traffic to a particular Ethernet port based on the 802.1Q tag.

VLANs can be used to group hosts together as if they exist physically on the same wire or alternatively, hosts that are already physically on the same wire can be logically separated.

VLANs are used to allow different logical networks to be connected to the same physical hardware without any cross-leakage of data from one VLAN to any other at layer 2.

For cross-communication between the VLANs, you need a router to route at the layer 3 level. The VLANs can be thought of as layer 2 broadcast domains.

The IEEE 802.1Q Ethernet frame is shown in figure 1. The VLAN ID specifies to which VLAN the Ethernet traffic belongs. This feature can be used to define a fixed voice VLAN, so that all VoIP telephones can be kept on a dedicated VLAN, with a higher layer switching at routers or switches.

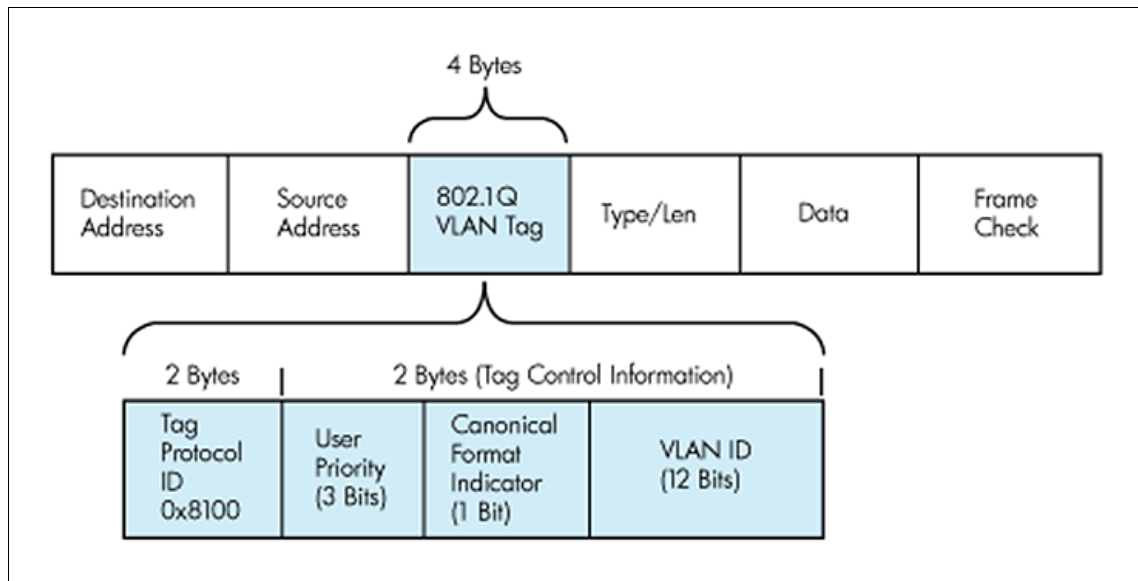

Figure 1: IEEE 802.1Q Ethernet tag

VLAN tagging is useful when VoIP telephones are used on internal networks. The QoS feature can be used to prevent timing-critical services, such as voice, from being interrupted by other less timing-sensitive services, such as data transmission.

As a security feature, the SMG allows the connection of different VLANs to different physical interfaces on the SMG, with only the inter-VLAN traffic being passed to the CPU/router. The allowed VLAN tags are configured on the router and any tagged traffic that does not belong to the allowed VLAN tags group will not be allowed.

2.1 Configuring the SMG for VLAN

The Virtual Access SMG has a 4 port Ethernet switch. This switch can be grouped as a complete segment or as individual segments.

To configure a global setting, from the SMG Start page, click **Advanced -> Expert view -> system -> Ethernet -> system**. The System page appears.

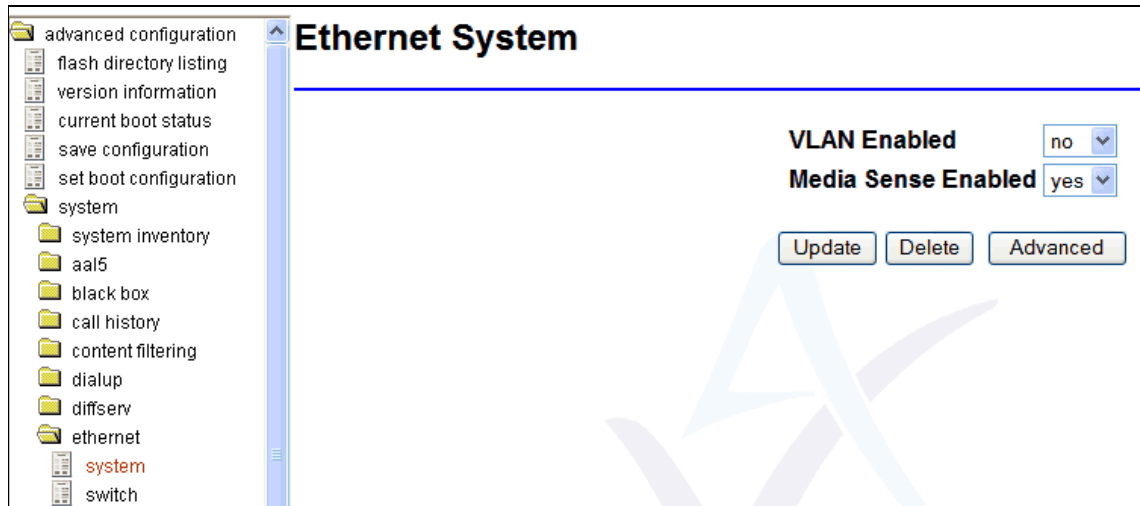

Figure 2: The Ethernet system page

Field name	Description	Command Line						
VLAN Enabled	Configures Ethernet switch for VLAN tagging.	Set Ethernet vlan tags enabled						
	<table border="1"> <thead> <tr> <th>Option</th> <th>Description</th> </tr> </thead> <tbody> <tr> <td>yes</td> <td>Enables VLAN</td> </tr> <tr> <td>no</td> <td>Disables VLAN</td> </tr> </tbody> </table>		Option	Description	yes	Enables VLAN	no	Disables VLAN
	Option		Description					
yes	Enables VLAN							
no	Disables VLAN							
Media Sense Enabled	Media Sense shows whether or not changes in the Ethernet physical state are reflected in the routing table. If disabled, the ports will always stay up at the IP level regardless of whether the physical cable is plugged or unplugged.	Set Ethernet media sense enabled						

Table 1: The Ethernet system fields and their descriptions

Note: when you have enabled the Ethernet switch for VLAN tagging, the Ethernet switch is no longer a segmented LAN and it defaults to a logical interface based on the assigned VLAN tags.

2.2 Configuring an individual interface for VLAN

To configure an interface setting, from the SMG Start page, click **Advanced -> Expert View -> interface -> eth-x -> vlan interface**. The Ethernet Interface page appears.

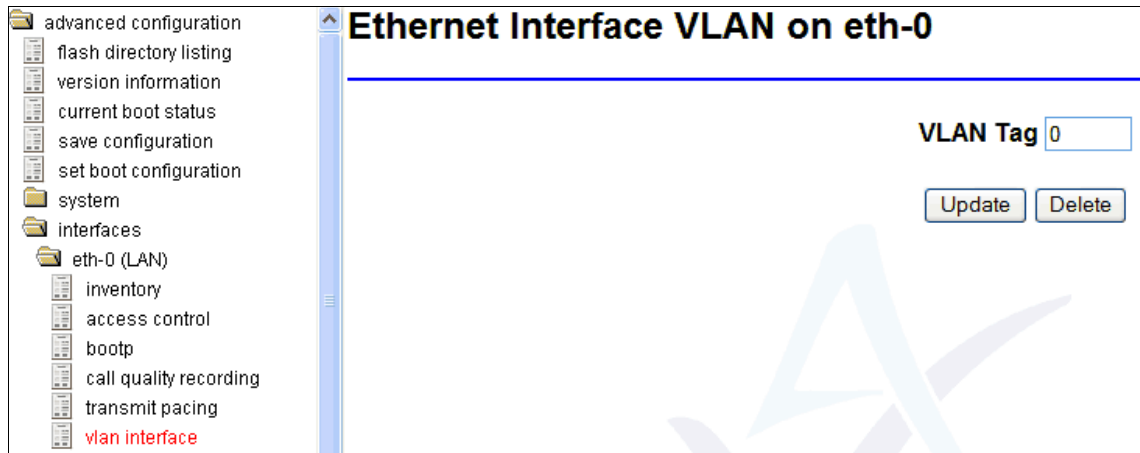

Figure 3: The Ethernet interface VLAN page

Field name	Description	Command Line										
VLAN Tag	<p>Defines the VLAN tag ID for a logical interface.</p> <table border="1"> <thead> <tr> <th>Option</th> <th>Description</th> </tr> </thead> <tbody> <tr> <td>Minimum value</td> <td>0</td> </tr> <tr> <td>Default value</td> <td>0</td> </tr> <tr> <td>Maximum value</td> <td>65535</td> </tr> <tr> <td>Units</td> <td>Unspecified</td> </tr> </tbody> </table> <p>Set the Ethernet interface VLAN tag to eth-x, y where x is the interface and y is the VLAN tag.</p>	Option	Description	Minimum value	0	Default value	0	Maximum value	65535	Units	Unspecified	Set Ethernet interface vlan tag
Option	Description											
Minimum value	0											
Default value	0											
Maximum value	65535											
Units	Unspecified											

Table 2: The VLAN tag field, description and command line

2.3 Viewing VLAN tags

When you have enabled VLAN tagging, to view your tags, from the Expert View Menu, click **operations -> performances -> interface stats -> VLAN table**. The VLAN Info page appears.

VLAN Tag	Logical If
0	Eth-0
100	Eth-1
200	Eth-2
300	Eth-3

Figure 4: The VLAN information page showing Ethernet VLAN mapping

Alternatively, you can use a Telnet session to issue the following command:

Show Ethernet vmap

VLAN Tag	Logical If
0	Eth-0
100	Eth-1
200	Eth-2
300	Eth-3

Port	Neg	S100	Fulldpx	Loopbk	Pwrdown	Isolate	Quality	Loop?
A	1	0	0	0	0	0	0	No
B	1	0	0	0	0	0	0	No
C	1	0	0	0	0	0	0	No
D	1	0	0	0	0	0	0	No

Table 3: Screen grab showing results of the show Ethernet vmap command

2.4 Deployment scenario example

The use of VLANs in a VoIP scenario is very important. You can use VLANs to optimise QoS control and to reduce the number of Ethernet cables used.

You can tag Voice traffic from the LAN to allow the SMG to apply the appropriate QoS settings.

When PCs and IP phones exist on separate VLANs, you can use a single Ethernet cable to daisy chain the PC from the back of the IP phone to reduce cable runs or the number of Ethernet ports used.

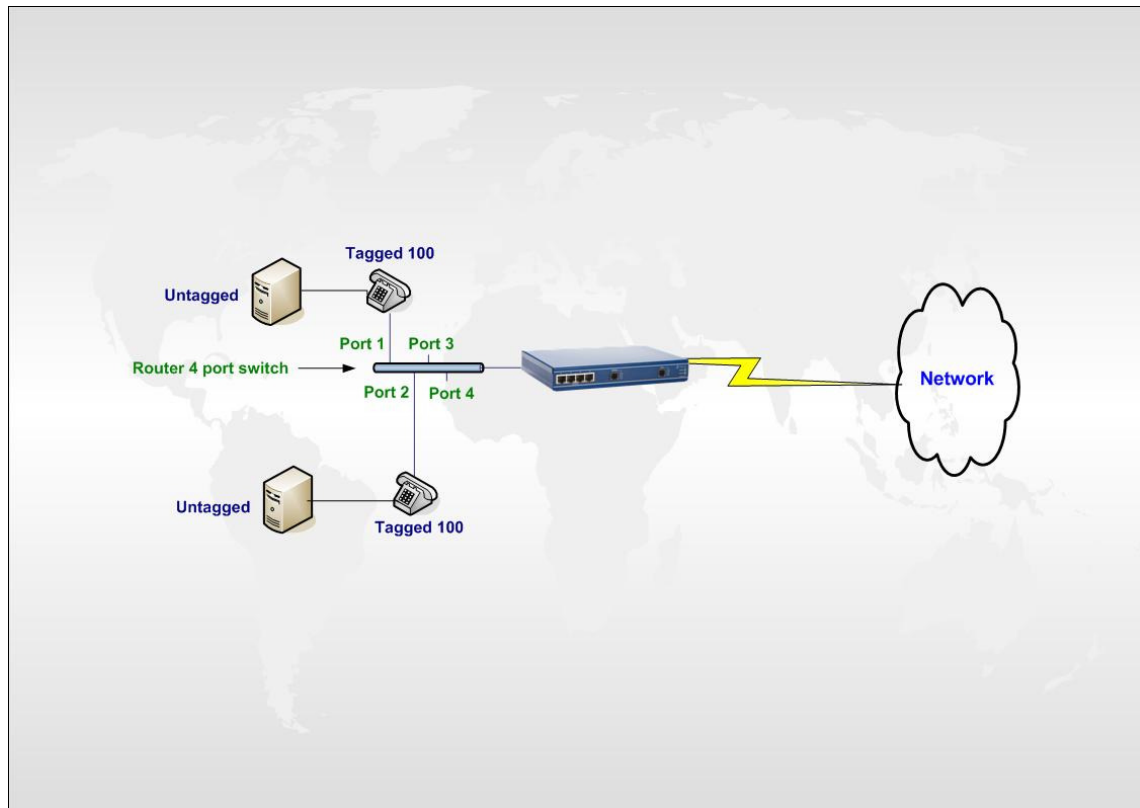

Figure 5: An example of a deployment scenario

Command Line
Set Ethernet interface vlan tag = eth-0,0
Set Ethernet interface vlan tag =eth-1,100
Set Ethernet VLAN tags enabled = yes

Table 4: Command lines used for the deployment scenario

2.5 Debugging VLAN

To view the Ethernet switch information, in the Expert View menu, click **operations -> performance -> interface stats -> ethernet switch**. The Statistics for Ethernet Switch page appears.

Statistics for Ethernet Switch

Port	MAC Address	Link	Speed	Duplex
A	00-e0-c8-00-b8-f9	yes	100	Full
B	00-e0-c8-80-b8-f9	no	-	-
C	00-e0-c8-40-b8-f9	no	-	-
D	00-e0-c8-c0-b8-f9	no	-	-

View active MAC addresses for

Port	MAC Address	Age
Port A	00-03-ff-1c-55-00	2
Port A	00-03-ff-19-55-01	2
Port A	00-00-5e-00-01-02	2
Port A	00-03-ff-1e-c0-03	2
Port A	00-1a-a0-b6-5a-04	2
Port A	00-11-43-be-88-07	2
Port A	00-08-c7-c5-c6-0f	3

Figure 6: The statistics for Ethernet switch page

Alternatively, you can use a Telnet session to issue the following commands:

Show switch info

Show switch table

3 CDP

The CDP feature on the SMG allows it to pass out CDP MAC address broadcasts. This broadcast can indicate to a client host what VLAN tag to use. Certain IP handsets are enabled as CDP clients by default.

This means that IP phones that are required to operate on a specific VLAN do not have to be pre-staged. In conjunction with Virtual Access' phone provisioning service, IP phones and routers can be shipped directly to a customer site requiring no pre-configuration.

3.1 Configuring the SMG for CDP

To configure the SMG for CDP, from the SMG Start page, click **Advanced -> Expert View -> system -> Ethernet -> CDP server**. The CDP Server page appears.

Figure 7: The CDP server page

Field name	Description	Command Line										
Enabled	Enables or disables CDP (Cisco Discovery Protocol) for advertising Voice VLAN ID. <table border="1"> <thead> <tr> <th>Option</th> <th>Description</th> </tr> </thead> <tbody> <tr> <td>yes</td> <td>Enables CDP</td> </tr> <tr> <td>no</td> <td>Disables CDP</td> </tr> </tbody> </table>	Option	Description	yes	Enables CDP	no	Disables CDP	Set cdp server enabled =yes				
Option	Description											
yes	Enables CDP											
no	Disables CDP											
Voice VLAN Id	Defines Voice VLAN Identifier to be advertised. <table border="1"> <thead> <tr> <th>Option</th> <th>Description</th> </tr> </thead> <tbody> <tr> <td>Minimum value</td> <td>1</td> </tr> <tr> <td>Default value</td> <td>1</td> </tr> <tr> <td>Maximum value</td> <td>65535</td> </tr> <tr> <td>Units</td> <td>Unspecified</td> </tr> </tbody> </table>	Option	Description	Minimum value	1	Default value	1	Maximum value	65535	Units	Unspecified	Set cdp server voice vlan identifier = 100
Option	Description											
Minimum value	1											
Default value	1											
Maximum value	65535											
Units	Unspecified											
Time to Live	Defines Time to Live for CDP	Set cdp server time to										

	broadcast. <table border="1"> <thead> <tr> <th>Option</th> <th>Description</th> </tr> </thead> <tbody> <tr> <td>Minimum value</td> <td>0</td> </tr> <tr> <td>Default value</td> <td>180</td> </tr> <tr> <td>Maximum value</td> <td>65535</td> </tr> <tr> <td>Units</td> <td>Secs</td> </tr> </tbody> </table>	Option	Description	Minimum value	0	Default value	180	Maximum value	65535	Units	Secs	live =180
Option	Description											
Minimum value	0											
Default value	180											
Maximum value	65535											
Units	Secs											
Broadcast Interval	Defines broadcast interval in seconds. <table border="1"> <thead> <tr> <th>Option</th> <th>Description</th> </tr> </thead> <tbody> <tr> <td>Minimum value</td> <td>1</td> </tr> <tr> <td>Default value</td> <td>60</td> </tr> <tr> <td>Maximum value</td> <td>65535</td> </tr> <tr> <td>Units</td> <td>Secs</td> </tr> </tbody> </table>	Option	Description	Minimum value	1	Default value	60	Maximum value	65535	Units	Secs	Set cdp Server Broadcast Interval
Option	Description											
Minimum value	1											
Default value	60											
Maximum value	65535											
Units	Secs											

Table 5: The CDP server fields, descriptions and their command lines

The critical setting is number Voice VLAN Id. This specifies the VLAN tag to offer as part of the CDP broadcast. Any host acting as a CDP client will use this tag.

3.2 CDP flows

The table below describes the flow and mapping between CDP and DHCP.

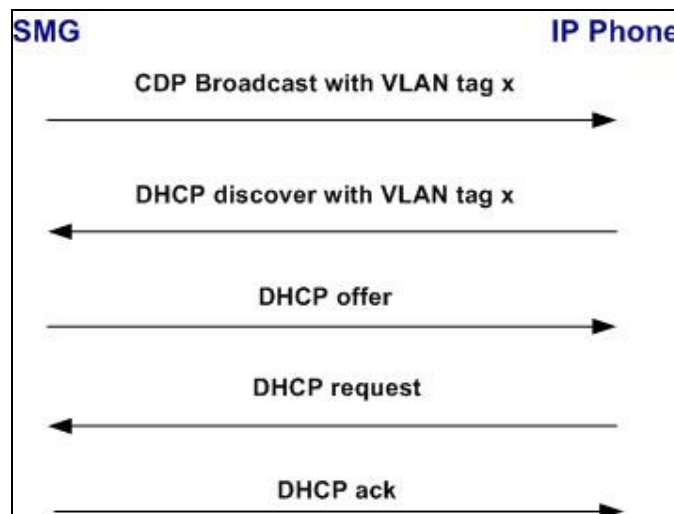

Figure 8: Flow and mapping between CDP and DHCP

3.3 Debugging CDP

3.3.1 Tracing using the command line

For information on logging on to the command line, read 'Managing the SMG via the Command Line' application guide.

Tracing via the command line is more flexible than using the trace analyser as you can specify the event severity and use the all class event to trace all event classes.

Command line tracing also allows you to trace to a log file for examining events over a protracted period of time.

If you enter no event severity, all event severities are displayed.

If you choose an event severity, all events of the chosen severity and greater are displayed.

To stop tracing, entering - (minus) followed by the event class will stop tracing for this event class. Entering - (minus) on its own will stop all tracing.

Syntax	Description
++cdp	Starts tracing CDP events
-cdp	Stops CDP tracing

Table 6: The command line tracing syntax and their descriptions

Show cdp server info

CDP Server info
Enabled: yes
Voice VLAN id: 100
Broadcast interval: 60
Time to live: 180

Table 7: Output from the CLI command show cdp server info